

kenera

BENTEC SLIP LIFTER

SL-1500-FN

HYDRAULIC TOOL FOR SAFE AND EFFICIENT TUBULAR HANDLING



The Bentec hydraulic slip lifter, SL-1500-FN, aims to promote efficient operations through reducing equipment handling to ultimately improve rig floor safety.

WHAT DOES IT DO?

Developed in conjunction with specific customer needs, the tool is used to lift rotary slips and secure tubulars in the Rotary Table (RT).

HOW DOES IT WORK?

Promoting a hands-off philosophy, the Slip Lifter has been designed as part of the pipe handling system. The SL-1500-FN is fully compatible with all market solutions, enabling use of existing control systems.

Equipped with interchangeable fork head mounting units, skidding plate and slip stabbing/adaptor guides to easily conform to various sizes of tubulars: slips, drill pipes and casings used.

As part of Kenera's approach to rig automation, the SL-1500-FN can be hydraulic remotely operated from the drillers cabin or safely positioned on the drill floor.

DESIGNED WITH EXPERTISE

Proven and proprietary technology from a company backed by more than 130 years of drilling rig and oilfield expertise to support your operations.

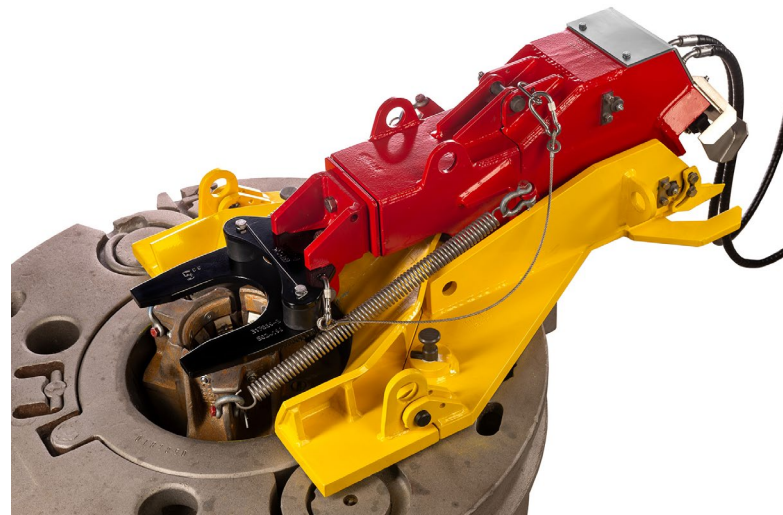

KEY BENEFITS

- ✓ Safety improvements – personnel removed from Red Zone
- ✓ Hands-off philosophy
- ✓ Ease of installation
- ✓ Fully compatible with other market solutions
- ✓ Field-proven design
- ✓ Speeds up tubular handling process
- ✓ Operated remotely by driller
- ✓ Component parts easily exchangeable

SPECIFICATIONS

Dimensions	Length: 41-2/3" / 1,056 mm Width: 27-7/8" / 708 mm Height: 17-1/3" / 440 mm
Weight	441 lbs / 200 kg
Min. handling dia.	2 3/8" / 60 mm (min.)
Max handling dia.	7 5/8" / 194 mm (max.)
Ambient temperature	-20°C to +55°C
Lifting capacity	1,500 lb / 680kg
Suitable for master bushings	37-1/2" & 27-1/2"
Locking device	Master bushing drive pins @ 25-3/4" pin circle

APPLICATIONS

- Suitable for NOV PS30 controls
- Compatible with API Rotary Tables (TR)

SUITABLE FOR

- Land or offshore rigs
- Arctic or desert environment

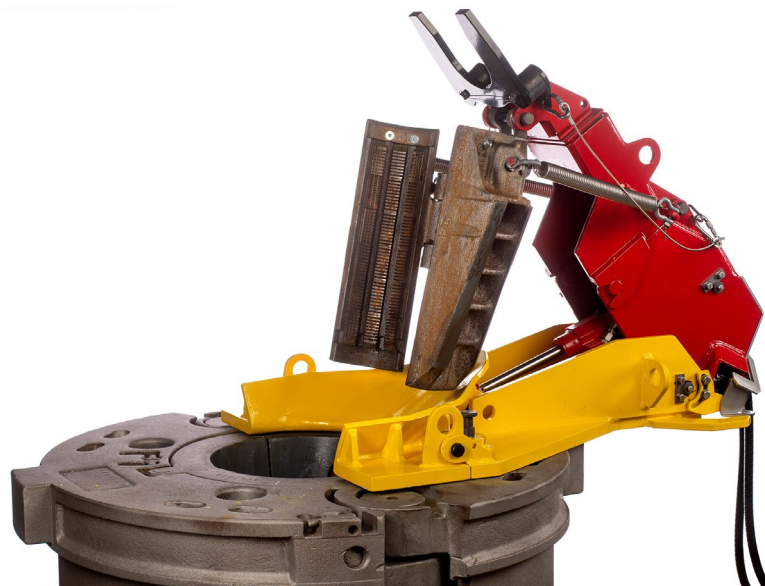
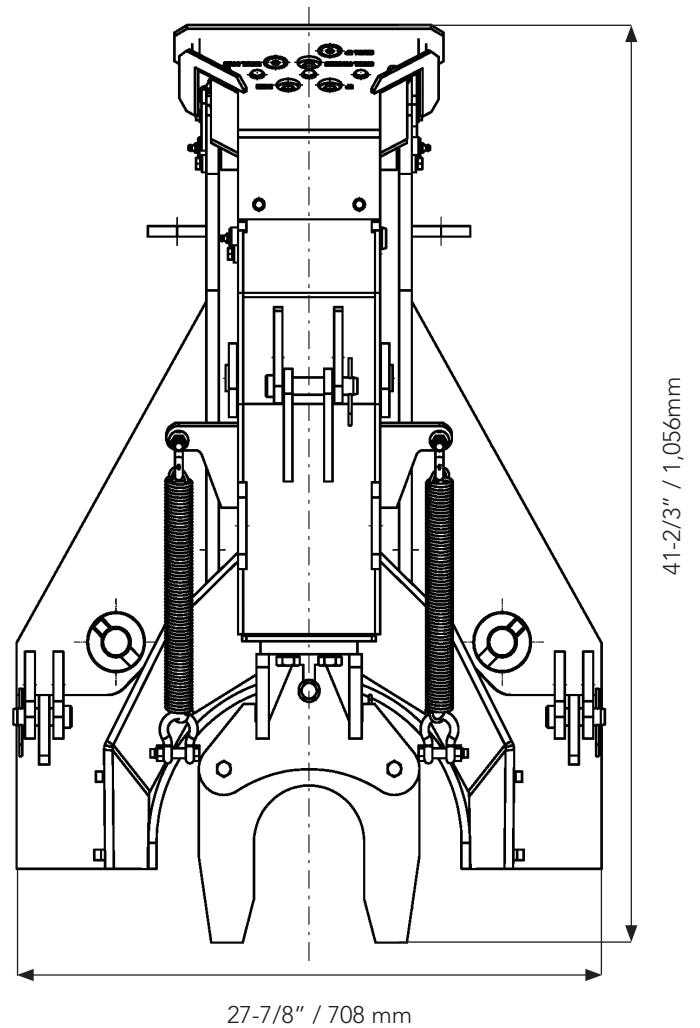

kenera



Visit www.kenera.com
Contact sales@kenera.com for the latest information

Part of the KCA Deutag Group

#enhancethebrand

bentec

Bentec GmbH Drilling & Oilfield Systems
is Kenera's rig equipment business

Details are subject to continual product development.
12077 April 2024